

# Hoist Plugs



The Hoist Plugs listed below are what we consider to be standard stock sizes but we can custom manufacture any pin or box thread.

Our Hoist Plugs are manufactured from 4142 Heat Treated Alloy Steel and can be customized to meet your individual requirements. Please contact us for pricing information.

Hoist Plug		Weight	
		Lbs.	Kgs.
HPMRJPS	MJR Pin Swivel Standard Duty	20	9
HPMRJPH	MJR Pin Swivel Hinged Standard Duty	22	10
HPMRJPSK	MJR Pin Swivel Standard Duty with Knocker Wheel	23	11
HPMRJPHK	MJR Pin Swivel Hinged Standard Duty with Knocker Wheel	25	12
HPMRPS	MR Pin Swivel Standard Duty	21	10
HPMRPH	MR Pin Swivel Hinged Standard Duty	23	11
HPMRPSK	MR Pin Swivel Standard Duty with Knocker Wheel	24	11
HPMRPHK	MR Pin Swivel Hinged Standard Duty with Knocker Wheel	26	12
HP2381FPS	2 3/8 IF Pin Swivel Standard Duty	28	13
HP2381FPH	2 3/8 IF Pin Swivel Hinged Heavy Duty	30	14
HP2381FSK	2 3/8 IF Pin Swivel Heavy Duty with Knocker Wheel	34	16
HP2381FHK	2 3/8 IF Pin Swivel Hinged Heavy Duty with Knocker Wheel	35	16
HP2781FPSHD	2 7/8 IF Pin Swivel Heavy Duty	32	15
HP2781FPHHD	2 7/8 IF Pin Swivel Hinged Heavy Duty	33	15
HP2781FPSKHD	2 7/8 IF Pin Swivel Heavy Duty with Knocker Wheel	36	17
HP2781FPHKHD	2 7/8 IF Pin Swivel Hinged Heavy Duty with Knocker Wheel	38	18

We also stock 2 3/8 FEDP Pin, 2 7/8 FEDP Pin and Mayhew Full Hole Pin but they are manufactured in smaller quantities which results in a little higher cost than those listed in the table above.

Standard Hoist Plugs have a 1 1/8 stem and 3/4 bail and Heavy Duty have a 1 1/2 stem with 1 inch bail.

We can manufacture hoist plugs with any pin or box connection that you require for your system. We have over 600 different thread gages in stock.

"PLEASE CALL FOR CUSTOM OPTIONS AND OTHER ACCESSORIES"

Check our Web Site:  
[www.MillsMachine.com](http://www.MillsMachine.com)

MILLS MACHINE CO. INC., P O BOX 1514, SHAWNEE, OK, 74802  
 Phone: 800-654-2703 or 405-273-4900 Fax: 405-273-4956

0103

9-1

# Murphy® Fast Plugs

## Murphy® Fast Plug - Swivel with Cast Bail

Part #	Connection	Bail Description	Weight	
			Lbs.	Kgs.
MFPNWJPCB	NWJ PIN	SWIVEL CAST BAIL		
MFPMJPCB	MAYHEW JUNIOR PIN	SWIVEL CAST BAIL		
MFPMRPCB	MAYHEW REGULAR PIN	SWIVEL CAST BAIL		
MFP238IFPCB	2 3/8 IF PIN	SWIVEL CAST BAIL		
MFP238FEDPPCB	2 3/8 FEDP PIN	SWIVEL CAST BAIL		

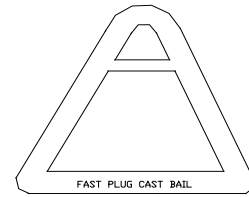

## Murphy® Fast Plug - Swivel with Mills Machine Bail

MFPNWJPMB	NWJ PIN	SWIVEL MILLS BAIL		
MFPMJPMB	MAYHEW JUNIOR PIN	SWIVEL MILLS BAIL		
MFPMRPMB	MAYHEW REGULAR PIN	SWIVEL MILLS BAIL		
MFP238IFPMB	2 3/8 IF PIN	SWIVEL MILLS BAIL		
MFP238FEDPPMB	2 3/8 FEDP PIN	SWIVEL MILLS BAIL		
MFP278IFPMB	2 7/8 IF PIN	SWIVEL MILLS BAIL		
MFP278FEDPPMB	2 7/8 FEDP PIN	SWIVEL MILLS BAIL		
MFP350IFPMB	3 1/2 IF PIN	SWIVEL MILLS BAIL		

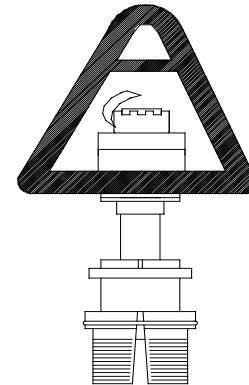

## Murphy® Fast Plug - Swivel Hinged with Mills Machine Bail

MFPNWJPHMB	NWJ PIN	SWIVEL HINGED MILLS BAIL		
MFPMJPHMB	MAYHEW JUNIOR PIN	SWIVEL HINGED MILLS BAIL		
MFPMRPHMB	MAYHEW REGULAR PIN	SWIVEL HINGED MILLS BAIL		
MFP238IFPHMB	2 3/8 IF PIN	SWIVEL HINGED MILLS BAIL		
MFP238FEDPPHMB	2 3/8 FEDP PIN	SWIVEL HINGED MILLS BAIL		
MFP278IFPHMB	2 7/8 IF PIN	SWIVEL HINGED MILLS BAIL		
MFP278FEDPPHMB	2 7/8 FEDP PIN	SWIVEL HINGED MILLS BAIL		
MFP350IFPHMB	3 1/2 IF PIN	SWIVEL HINGED MILLS BAIL		

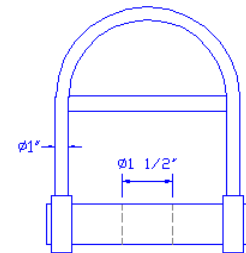

HEAVY DUTY SWIVEL-HINGE TYPE BAIL

## Murphy® Fast Plug Bodies Only

MFPNWJPB	NWJ PIN	NO BAIL		
MFPMJPB	MAYHEW JUNIOR PIN	NO BAIL		
MFPMRPB	MAYHEW REGULAR PIN	NO BAIL		
MFP238IFPB	2 3/8 IF PIN	NO BAIL		
MFP238FEDPPB	2 3/8 FEDP PIN	NO BAIL		
MFP278IFPB	2 7/8 IF PIN	NO BAIL		
MFP278FEDPPB	2 7/8 FEDP PIN	NO BAIL		
MFP312IFPB	3 1/2 IF PIN	NO BAIL		

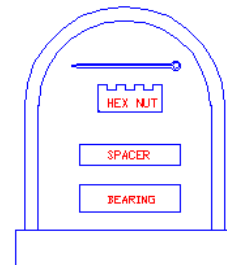

SWIVEL TYPE BAIL

We stock the springs (with shoulder washer), O-rings and 1 1/8 stem cast bails for the Murphy® Plugs. Call for pricing.

Murphy® is a Registered trademark of Lee Murphy Equipment Company.

"PLEASE CALL FOR CUSTOM OPTIONS AND OTHER ACCESSORIES"

# Hoist Plug Components

## Standard Duty

Part #	Description	Weight	
		Lbs.	Kgs.
HPB118S	Hoist Plug Bail - 1 1/8 Swivel	8	4
HPB118H	Hoist Plug Bail - 1 1/8 Swivel Hinged	10	5
HPBT113	Standard Hoist Plug Bearing – 1 1/8 Stem	.4	.2
HPS50125	Standard Hoist Plug Spacer – 1 1/8 Stem	.7	.4
CP143	Hoist Plug Cotter Pin – Standard & Heavy Duty	.1	.1

## Heavy Duty

HPB112S	Hoist Plug Bail – 1 1/2 Swivel	10	5
HPB112H	Hoist Plug Bail – 1 1/2 Swivel Hinged	12	6
HPBT151	Standard Hoist Plug Bearing – 1 1/2 Stem	.9	.5
HPS50150	Heavy Duty Hoist Plug Spacer – 1 1/2 Stem	.7	.4

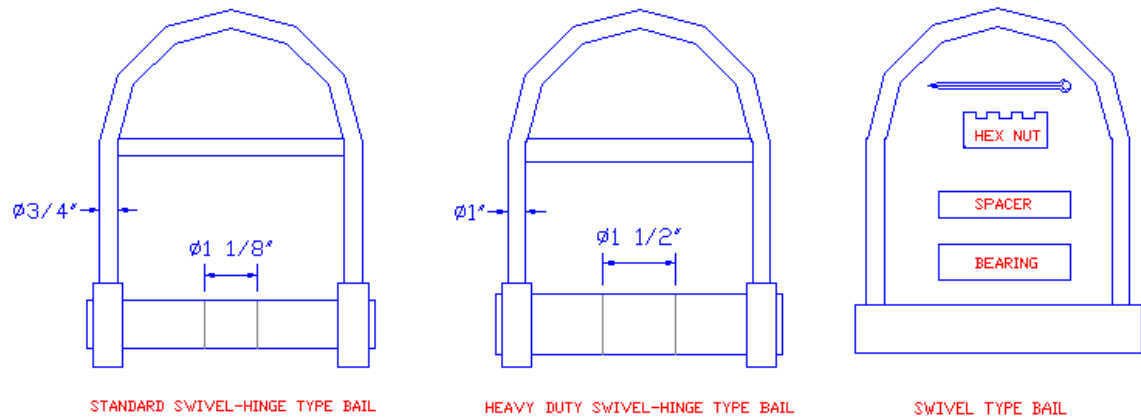

"PLEASE CALL FOR CUSTOM OPTIONS AND OTHER ACCESSORIES"

Check our Web site:  
[www.MillsMachine.com](http://www.MillsMachine.com)

MILLS MACHINE CO. INC., P O BOX 1514, SHAWNEE, OK, 74802  
 Phone: 800-654-2703 or 405-273-4900 Fax: 405-273-4956

0303

9-3

# Pipe Elevators

## Steel Pipe Elevators

Part #	Pipe Size		Weight	
	ID of Pipe	OD of Pipe	Lbs.	Kgs.
SPE0100	1"	1 5/16"	10	4.5
SPE1250	1 1/4"	1 5/8"	11	5.0
SPE0150	1 1/2"	1 7/8"	12	5.4
SPE0200	2"	2 3/8"	16	7.3
SPE0250	2 1/2"	2 7/8"	17	7.7
SPE0300	3"	3 1/2"	22	10.0
SPE0350	3 1/2"	4"	24	10.9
SPE0400	4"	4 1/2"	24	10.9
SPE0450	4 1/2"	5"	24	10.9
SPE0500	5"	5 9/16"	27	12.2
SPE0600	6"	6 5/8"	38	17.2
SPE0800	8"	8 5/8"	88	39.9
SPE1000	10"	10 3/4"	108	49.0
SPE1200	12"	12 3/4"	130	59.0
SPE1400		14"	139	63.1
SPE1600		16"		

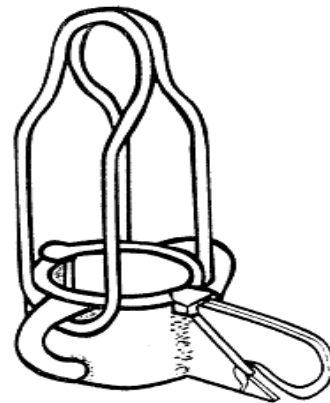

**Sold Separately, Not as a Set**  
 Will not work on flush joint pipe.  
 Size 10 and up have removable bail for ease of handling.

## PVC Pipe Elevators

Part #	Pipe Size		Weight	
	Casing Size	Elevator OD	Lbs.	Kgs.
PVCPE200	2"	2 3/8"	15	6.8
PVCPE300	3"	3 1/2"	18	8.2
PVCPE400	4"	4 1/2"	22	10.0
PVCPE412	4 1/2"	5"	22	10.0
PVCPE500	5"	5 1/2"	24	10.9
PVCPE600	6"	6 5/8"	26	11.8
PVCPE614	6 1/4"	6 7/8"	26	11.8
PVCPE800	8"	8 5/8"	32	14.5
PVCPE1034	10"	10 3/4"	56	25.4
PVCPE1234	12"	12 3/4"	60	27.2
PVCPE1600	16"	16 3/4"	60	27.2

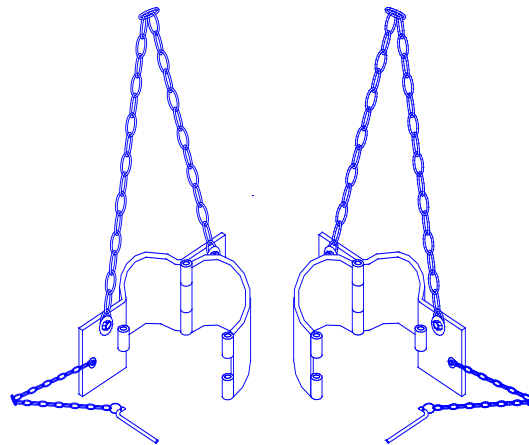

**Sold in Sets of Two Pieces.**  
 1/4 Steel Construction.  
 Safer than Ropes or Loop Chains.

**You must provide Outside and Inside Diameter of pipe!**

"PLEASE CALL FOR CUSTOM OPTIONS AND OTHER ACCESSORIES"

# Pipe Handling Tools

## Lifting Plugs

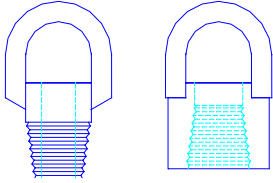

Lifting plugs (non swivel) are used to handle heavy equipment such as hammers, rock bits, stabilizers, and hole openers. They are made from 4142 heat-treated alloy steel with heavy duty fabricated bails. The lifting plugs are available with any pin or box thread.

## Pipe Tongs

Pipe tongs are designed for making up and breaking out drill pipe, casing and pneumatic drills on light rigs. Tongs come with chain and heavy-duty bolts that make it easy to quickly change from one diameter pipe to another. Required formation: pipe diameter, type of tong (buck-up, bull or drill pipe, etc.) and handle length.



## Casing Slips



Casing slips are available to meet your specific steel pipe diameter or as an adjustable slip. The adjustable type handles 1 1/2 through 8 5/8 OD. These slips feature a fabricated steel construction with replaceable alloy dies, the casing slips are used to hold drill pipe, pump drop pipe or any steel pipe or casing.

## PVC Pipe Clamp

Adjustable PVC pipe clamps are available in three size ranges: 1/2 to 2, 2 to 6 and 8 to 10. These clamps are easy to use and require no inserts. Made with an alloy aluminum base, they are lightweight and portable.



## Pipe Alignment Clamp



- Ratchet closure for speed and ease of aligning pipe ends.
- Precision machined to facilitate a close tolerance alignment for welding.
- Heavier and larger crossbars to assure straight alignment between the two joints of pipe.
- Wider stance for the roundabouts or sides of the clamp insure a firmer and more secure hold on the pipe ends.
- Also available with arched cross bars to allow full circle welding without removing the clamps.

“PLEASE CALL FOR CUSTOM OPTIONS AND OTHER ACCESSORIES”

# Pipe Handling Tools

---

## Steel Casing Holder

---

- Available with mechanical, air or hydraulic slip actuation.
- Inclined wedge holding system, no shoulder required.
- Thirty-five ton holding capacity.
- Can be installed above or below drilling table.

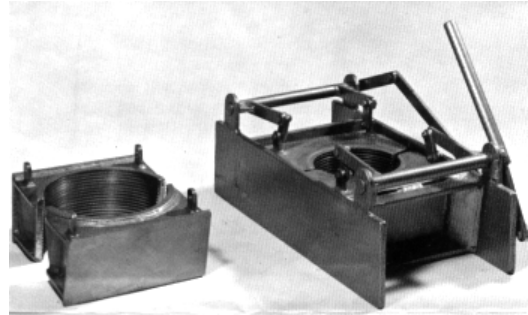

## Casing Lifter

---

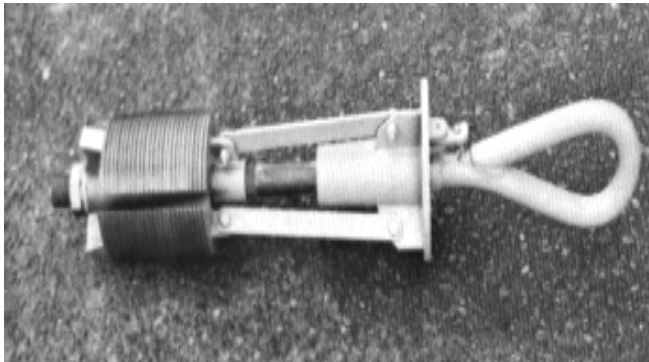

- Quickly elevates horizontal casing from ground or truck.
- Provides perfect vertical alignment for casing coupling or welding.
- Can be installed or released in seconds.
- Holding tension increases as more weight is lifted.
- Positive force locking system prevents accidental release.
- Eliminates the use of clamps and lugs.
- Thirty-five ton holding cap.

"PLEASE CALL FOR CUSTOM OPTIONS AND OTHER ACCESSORIES"